

SB-4L-1 Blender (220-240 V)

No. on drawing	Item No.	Spare Part	Reservdel	Incl.Pcs
10	23142	SUPPORT,LID	LOCKHÅLLARE	1
20	23171	PLUG FOR CAMSHAFT	TÄCKPROPP F. KAMAXEL	1
30	23157	CAMSHAFT	KAMAXEL	1
40	23166	SPRINGBLADE	BLADFJÄDER	1
50	14339	SCREW MRX-H M5x12 A2 70	SKRUV MRX-H M5x12 A2 70	6
60	14085	LOCK WASHER FBB 5,1 A2	BRICKA FJÄDER FBB 5.1 A2	6
70	15566	MICRO SWITCH MZTI361308 230V	MIKROBRYTARE MZTI361308 230V	1
80	14065	WASHER	BRICKA BRB 5.3x10x1 A2	2
90	15710	PC-BOARD 230V SB-4L	ELEKTRONIKKORT 220-240 1 50/60	1
100	23314	PROTECTION PLATE, AM	TÄCKPLÅT, GALLER AM	1
110	23313	BRACKET, MICROSWITCH 120-240V	FÄSTPLÅT, MIKROBR. 120-240V	1
120	15527	BRACKET FOR PC-BOARD AVC BS-9A	KORTHÅLLARE AVC BS-9A	4
130	23145	LOUVER	VENTILATIONSGALLER	1
140	14223	SCREW MKFS M4x10 A2 70	SKRUV MKFS M4x10 A2 70	2
150	14332	SCREW MRX-H M4x10 A2 70	SKRUV MRX-H M4x10 A2 70	5
160	14084	LOCK WASHER FBB 4.1 A2	BRICKA FJÄDER FBB 4.1 A2	4
170	14004	NUT M6M M4 A2 70	MUTTER M6M M4 A2 70	1
190	15555	CABLE RETAINER 1397 SR-17-2	DRAGAVLASTARE 1397 SR-17-2	1
220 1)	23323	SUPPLY CORD, SB-4L-1	SLADDSTÄLL, SB-4L-1	1
221 1)	23238	SUPPLY CORD 240V AUS	SLADDSTÄLL 240V SB-4 BONN	1
222 1)	23239	SUPPLY CORD 240V UK	SLADDSTÄLL 240V UK	1
230	23158	MACHINE HOUSING	MASKINHUS	1
240	15709	MOTOR 220-240 1 50/60	MOTOR 220-240 1 50/60	1
250	23315	MOTOR PLATE	MOTORPLÅT	1
260	14065	WASHER	BRICKA BRB 5.3x10x1 A2	4
270	10551	BELT POWER GRIP 5MR 0400 12	KUGGREM 5MR 0400 12	1
280	14424	SCREW LSKS M4X12 A2 70	SKRUV LSKS M4x12 A2 70	1
290	23312	PROTECTION PLATE	BOTTENPLÅT	1
300	15357	CABLE CLAMP NK-4 N	KABELKLÄMMA NK-4 N	2
310	23197	POTENTIOMETER OMEG	POTENTIOMETER OMEG	1
320	10507	FOOT,RUBBER BVO 22H10	FOT,GUMMI BVO 22H10	4
330	40786	SCREW FOR RUBBERFOOT	SKRUV FÖR GUMMIFOT	4
340	23148	KNOB,INDIKATOR	VRED	1
350	23144	SUPPORT FOR BOWL	BUFFERT	4
360	14755	SCREW PT 5X20 Z A2	SKRUV PT 5X20 Z A2	8
370*	23246	JUG 4L	KANNA 4L	1
380*	23141	LID	LOCK	1
390	23167	DOSING FEEDER	OLJEDOSERARE	1
400*	23308	KNIFE UNIT COMPL.	KNIVLAGRING KOMPL. (NY KNIV)	1
410	14028	NUT MHM M8 A2 70	MUTTER HATT MHM M8 A2 70	1
430	23268	KNIFE OVER, MO03	KNIV ÖVER L=72 MO03	1
450	23269	KNIFE UNDER, MO03	KNIV UNDER L=72 MO03	1
470	10539	O-RING 21.1x1.6	O-RING 21.1x1.6	1
510	23231	NUT M22X1	MUTTER M22X1	1
520	23161	WASHER FOR COUPLING	BRICKA F.KOPPLING	1
530	23173	COUPLING, MACHINE	KOPPLING, MASKIN	1
540	14078	WASHER	BRICKA BRB 4,3X12X1,5 A2	1
550	14501	SCREW M6S M4x8 A2 70	SKRUV M6S M4x8H A2 70	1
560	23150	SPACER RING L=4	DISTANSRING L=4	1
570	23138	DRIVE SHAFT COMPL.	DRIVAXEL KOMPLETT	1
580	10538	BALLBEARING 608-2RS	KULLAGER 608-2RS	2
590	23172	COVER, BEARING	LAGERLOCK	1
600	23121	PULLEY WITH SHAFT	REMHJUL INKL AXEL	1
610	23322	PUSH BUTTON,PULSE COMPL.	PULSKNAPP KOMPL.	1
620	23253	COUPLING COMPL. M6, JUG	KOPPLINGSHALVA KOMPL. M6, KANN	1
630	23248	KNIFE COVER	KNIVSKYDD	1
640	24138	BLADE SPRING FOR KNOB	BLADFJÄDER, VRED	1
*370, 400	23309	CONTAINER 4L. INCL.KNIFE UNIT	KANNA (M. NY KNIV), UTAN LOCK	1
*370,380,400	23307	CONT. 4L. INCL. KNIFE UNIT,LID	KANNA (POLYSUL), 4 L MED LOCK	1

1) Damaged Supply Cord has to be replaced by cable type S32/H05VVf, 3*1,5 mm², 2,4 m

Drawing: Blender SB-4L-1

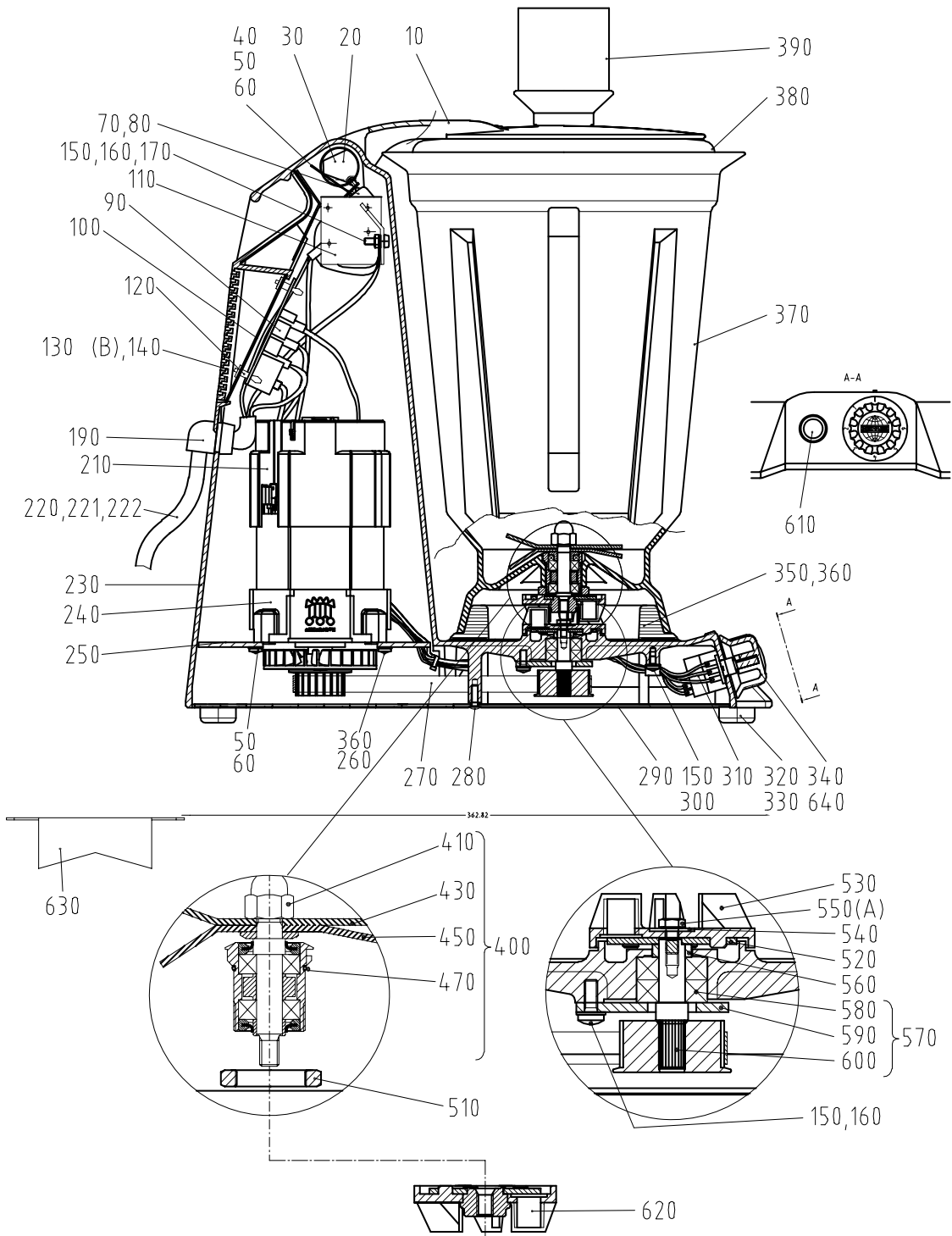

A: LOCTITE NO. 242
 B: SILICONE RTV 108

05-09-15 R:RITNING/DIV/RESERVD/RITNING/SPAREPARTSSB4L